

DESUPERHEATER INSTALLATION, OPERATION & MAINTENANCE MANUAL

This manual contains information which may be helpful in the installation of freon and ammonia vented double wall desuperheaters and condensers.

TRANSIT

Responsibility for any in-transit damage rests with the carrier for all products manufactured by doucette industries, inc. that are sold FOB York, PA.

CAUTION: ALL PRODUCTS SHOULD BE CAREFULLY INSPECTED BY THE RECEIVER PRIOR TO DELIVERY ACCEPTANCE.

If any damage is found, a complete description including type and extent should be noted on carrier's delivery receipt or bill of lading and a claim filed **IMMEDIATELY**.

MOVING

When moving and/or lifting the unit, equipment of suitable capacity must be used. If there is any doubt about the weight of the unit to be lifted, check with the factory before proceeding. The figure below shows a proper lifting configuration being employed.

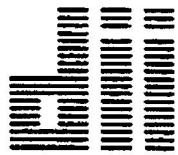
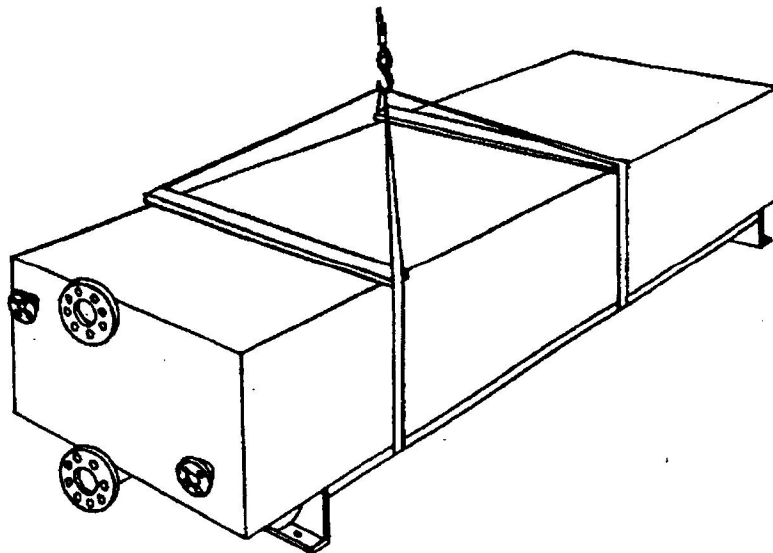

doucette industries, inc

701 Grantley Road, York, PA 17403-3525 Fax# 717/845-2864 Phone# 717/845-8746

TOLL-FREE 800-445-7511

DESUPERHEATER INSTALLATION INFORMATION

MOUNTING

The desuperheater should be mounted in an upright (mounting legs down), horizontal position and be level in all directions for optimum performance. Mounting holes are provided on the unit legs, and bolts of adequate size and strength should be employed to properly secure the unit. Adequate clearance must be provided between the cleanable end of the unit and any wall or obstruction so that the water tubes may be cleaned.

PLACEMENT

Every attempt should be made to locate the outlet gas connection of the desuperheater above the inlet connection to the condenser so that any oil or liquid condensate can drain directly into the condenser by gravity. The figure below shows a typical arrangement in which the desuperheater is correctly placed above the condenser.

If the desuperheater must be placed below the level of the condenser, then a drop leg and a p-trap must be provided at the outlet of the desuperheater. The p-trap should be drained with a float valve to the high pressure receiver or other system pressure vessel operating at lower than condensing pressure.

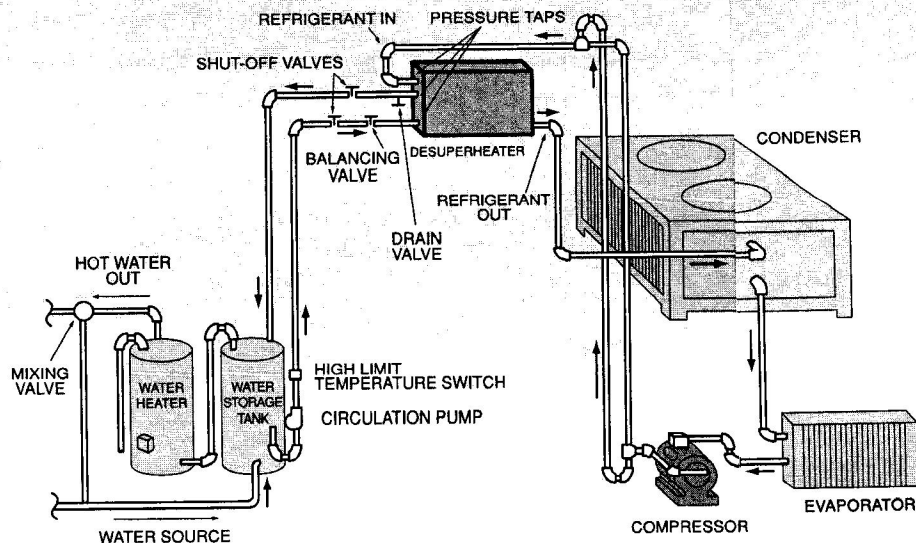

DESUPERHEATER INSTALLATION INFORMATION

PIPING

The desuperheater/condenser should be installed in the discharge line of the compressor after the discharge muffler or oil separator and before the condenser. Block valves should be installed on the entering and leaving refrigerant lines, as well as in a by-pass line, so that the desuperheater/condenser can be isolated for service. It is important to support these valves as well as any additional piping independently of the unit.

CAUTION: ADEQUATE PROVISION FOR PIPE SUPPORT AND EXPANSION-CONTRACTION MUST BE MADE NEAR THE DESUPERHEATER TO INSURE THAT THE UNIT ITSELF IS NOT BEARING ANY LOAD. FAILURE TO PROPERLY SUPPORT PIPING CONNECTIONS AND ASSOCIATED HARDWARE MAY RESULT IN DAMAGE TO THE UNIT AND VOID THE LIMITED WARRANTY.

The figure below indicates a typical large desuperheater with the piping connections identified. If there are any questions regarding these piping arrangements, consult the factory.

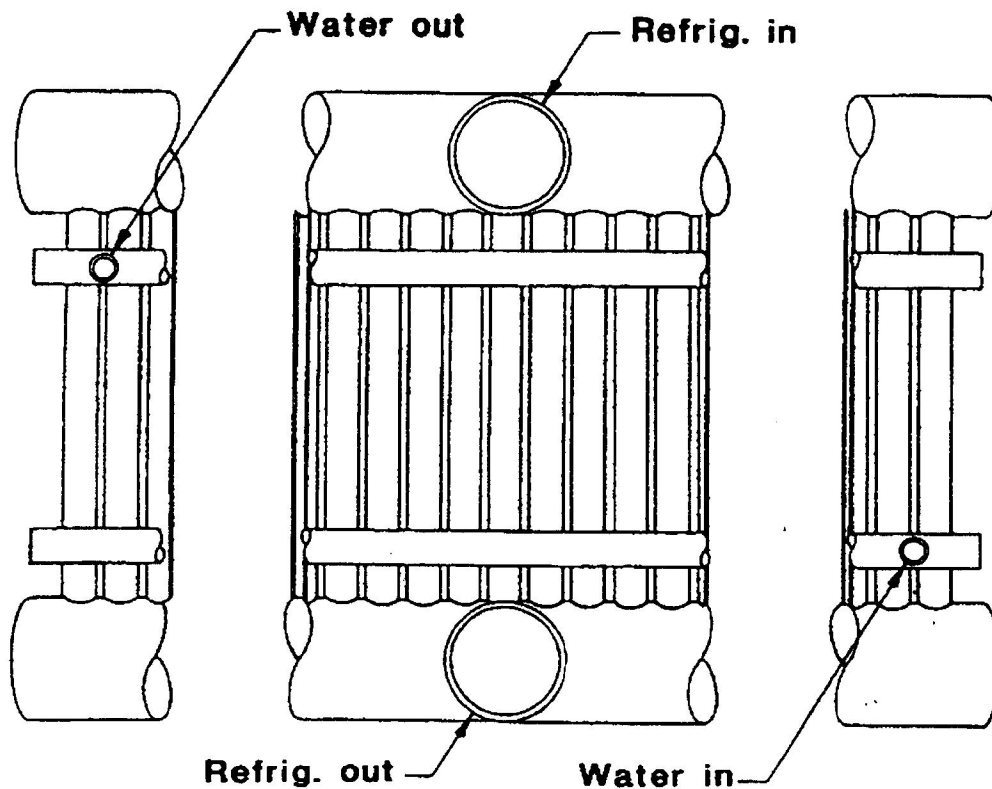

DESUPERHEATER INSTALLATION INFORMATION

WATER CONNECTIONS

All water side piping, including the desuperheater, should be thoroughly flushed with fresh, clean water prior to connecting to the service line. Acidic solutions are not necessary in the desuperheater and should be avoided when the device is to be used to heat potable water. (See maintenance section for cleaning procedure). Should there be a danger of the desuperheater being subjected to subfreezing temperatures, vent and drain valves must be provided at the high and low points so that the desuperheater can be thoroughly and completely emptied of water.

As with the refrigerant piping, the water-side connecting piping should be supported as close as possible to the unit to prevent stressing the water tube joints. Appropriate shutoff and bypass valves should be provided.

At low water flows, very high water temperatures are possible. Tempering valves should be used when directly connected to a potable water system.

CAUTION: PVC (PLASTIC) PIPE AND FITTINGS MAY SAG OR FAIL WHEN SUBJECTED TO WATER TEMPERATURES ABOVE 150F.

REFRIGERANT CONNECTIONS

Extreme care should be taken to prevent oil or liquid condensate from being trapped in the refrigerant piping. The refrigerant out connection of the desuperheater should be the highest point in the lines connecting the desuperheater and the condenser, unless provision is made to handle these fluids. It is good practice to insulate the compressor discharge line to assure maximum energy recovery and efficiency of the system. The insulation should be able to withstand extended periods of time at the discharge temperature of the compressor.

PRE-OPERATION

If the desuperheater will be exposed to subfreezing temperatures, care must be taken to insure against freezing which may lead to tube rupture. Typically, thermostatically controlled heat tape is selected to provide adequate freeze protection at the lowest anticipated temperature. The heat tape manufacturer's instructions should be followed for proper installation.

DESUPERHEATER OPERATION INFORMATION

OPERATION

The figure below illustrates, in detail, the water and refrigerant circuiting and flow through a 12 tube, 3 pass desuperheater.

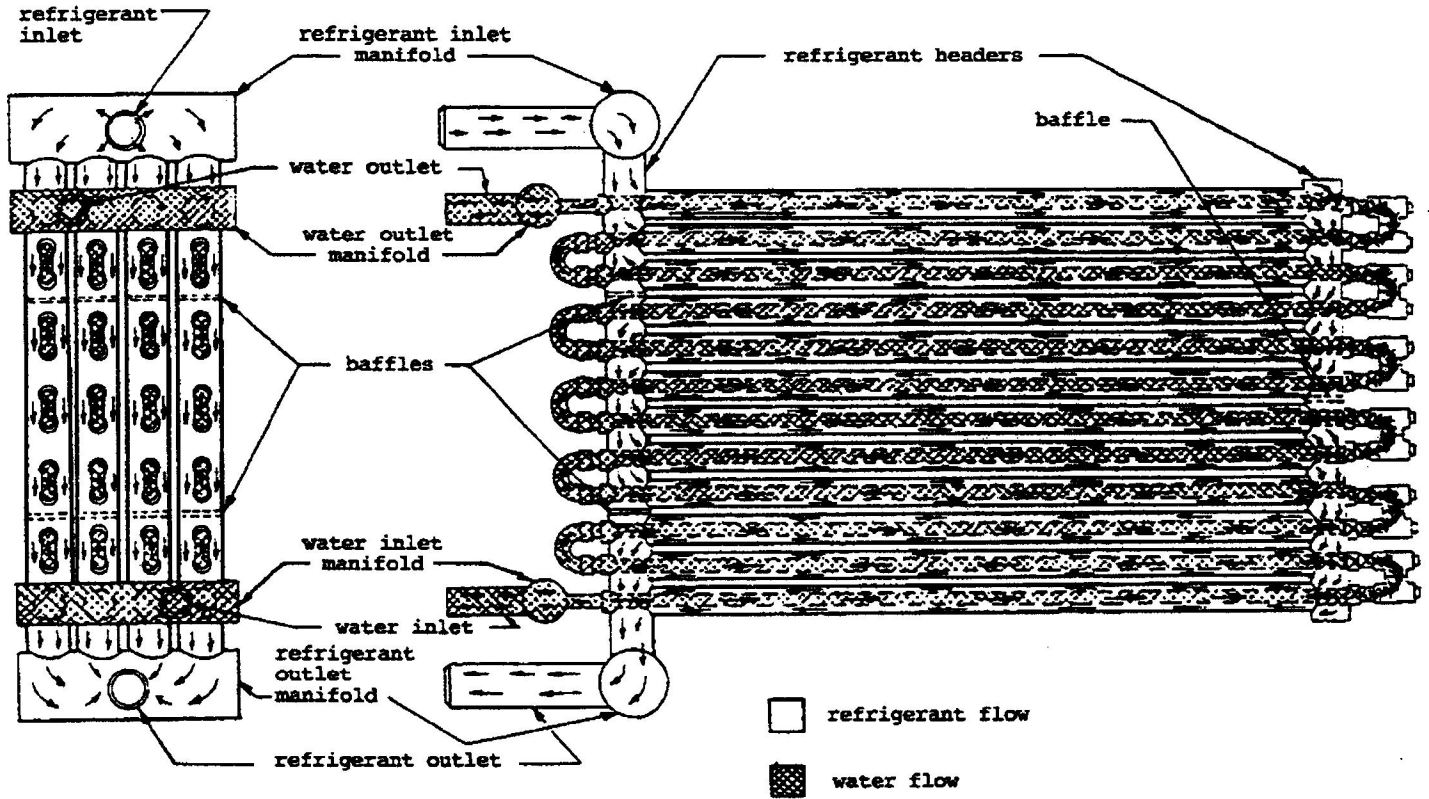

DESUPERHEATER OPERATION INFORMATION

UNIT OPERATION

High temperature discharge gas enters the unit through the refrigerant inlet and is distributed to the individual sections via the inlet manifold. The refrigerant flows downward through the vertical refrigerant headers and is distributed to the individual tubes. In the case illustrated, there are three parallel passes which are used to control the refrigerant pressure drop. The number of passes in any given desuperheater is determined by the baffle placement in the refrigerant header. The refrigerant is forced through the top three tubes and over the enhanced surface of vented double wall water tube. After traversing the length of the first three tubes, the refrigerant is collected in the other header and forced to return through the next row of three tubes. It then proceeds in like manner until it is collected in the refrigerant outlet manifold to be discharged to the condenser.

Simultaneously, cold water enters the unit through the water inlet and flows upward, opposite to the refrigerant flow. As the water flows up through the continuous flow path, heat contained in the refrigerant gas is transferred to the water.

If a leak should develop on either the water side or the refrigerant side of the internal, double wall tube, the leaking fluid will spiral through the vent path and exit at both ends of the unit. The double wall spiral is shown in the figure below.

CAUTION: IN THE EVENT OF A LEAK, TAKE THE UNIT OUT OF SERVICE AND CONTACT THE MANUFACTURER IMMEDIATELY. ANY ATTEMPT TO REPAIR A LEAK BY SEALING THE VENT PATH NOT ONLY VOIDS THE LIMITED WARRANTY, BUT CAN BE VERY DANGEROUS.

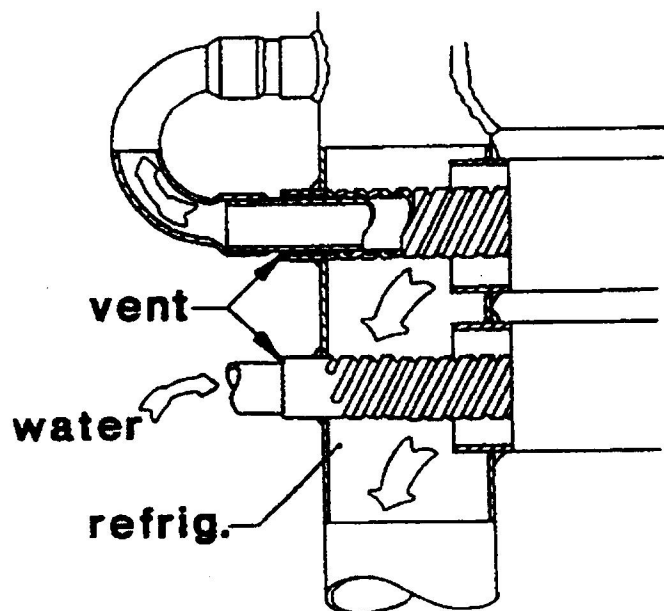

DESUPERHEATER MAINTENANCE INFORMATION

MAINTENANCE

- After several weeks of operation at elevated temperature, the clean out plugs should be checked for leakage. The Teflon tape sometimes relaxes enough to permit minor leakage which can be easily remedied by tightening the plugs.
- The unit should be inspected periodically for exterior wear. Any oxidized or otherwise weathered surfaces should be repaired.
- If the unit is to be shut down for extended periods of time, any exposed system piping should be fully drained to prevent freezing.
- The water tubes should be checked, and if necessary, cleaned at regular intervals.

WATER TUBE CLEANING

It is difficult to predict or suggest a water tube cleaning schedule. The scaling rate depends upon discharge temperature, water temperature, water flow rate, type and concentration of dissolved minerals and their seasonal variation and whether the system is open or closed. It is recommended that the desuperheater performance be closely monitored during the first few months of operation. If measurable deterioration in performance is detected, remove a single clean out plug from the upper portion of the unit and examine the water tube for scale. A cleaning schedule can then be established based upon this initial examination. If no significant deterioration in performance is noted after 3-4 months, cleaning may not be necessary for an extended period of time.

Should the desuperheater require cleaning the following procedure is recommended.

1. Open the refrigerant bypass valve and close the inlet and outlet refrigerant valves. If there are no isolation valves, the system should be shut down. If possible, the refrigerant pressure in the desuperheater should be reduced to near atmospheric pressure. This is not essential since the water and refrigerant circuits are not connected, but it is good practice to depressurize a component before performing mechanical maintenance on it.
2. Isolate the water circuit by closing the inlet and outlet valves and electrically disconnect pumps and heat tape. Open the vent and drain valves and drain the water from the unit.
3. Remove the access panel on the rear of the desuperheater cabinet which is normally on the end opposite the water and refrigerant connections. Care should be exercised in removing the bolts to insure that the access panel may be replaced easily.
4. Remove the clean out plugs from the high pressure fittings. (See figure on next page)

WATER TUBE CLEANING

5. Clean the tubes with the appropriately sized wire brush and flush thoroughly with water. Avoid excessive wear on copper water tubes.
6. Inspect the Teflon tape on each clean out plug prior to reinstallation and retape as necessary.
7. Open the water shutoff valve gradually and fill the unit from the bottom, purging all air from the vent valve as it fills. Tighten clean out plugs as necessary.
8. Reconnect power to the circulating pump and open the water valves.
9. Start the circulating pump and inspect the area around the clean out plugs.
10. Reconnect heat tape, if applicable.
11. Reassemble the cabinet, if applicable.
12. Pressurize refrigerant circuit by opening both inlet and outlet valves and then gradually closing the refrigerant bypass valve.

